

Selection form - flap valve

Customer: _____

Address: _____

Project: _____

No of flap valves: _____

1. Size and shape of the opening

round

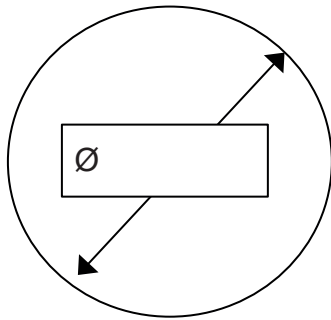

rectangular

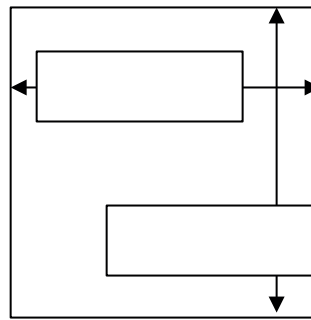

Please give all dimensions in mm

2. Installation

for dowelling

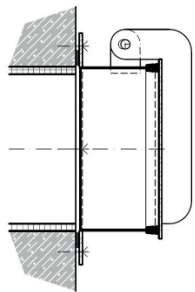

Connection to a flange

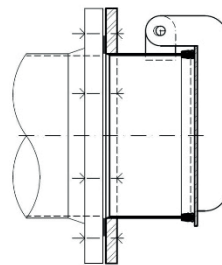

PN10 PN16

for embedding

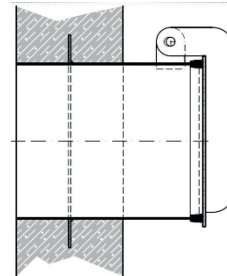

|<----->|

Supply fasteners (chem anchors/screws for flange)

3. Materials

Flap valve:

- Stainless steel 1.4301
- Stainless steel 1.4571
- Steel hot dip galvanized
- Other: _____

Sealing:

- EPDM
- NBR
- Other: _____

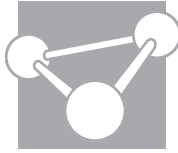

4. Counterweight

- Counterweight above, so to open at a low internal pressure
- Counterweight below, so to open at a stronger internal pressure
- The flap valve should open at a differential pressure of _____ mwc

5. Cover

- flat cover
- floating hollow cover
- angled cover, angle 10°
desired angle:

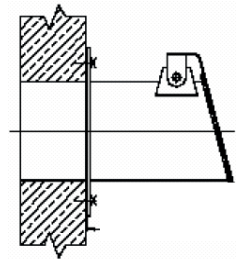
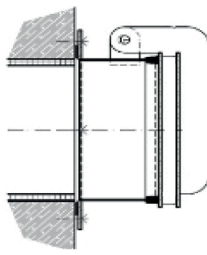
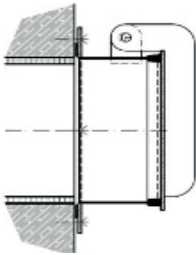

6. Features

- End stop damper, rubber dampened
- End stop damper, hydraulic, oil/water dampened (preferably with pump flaps)
- other: _____

Remarks:

Telephon/E-Mail (for inquiry calls):