



## Surface box cleaner

made of stainless steel

### Material

- Stainless steel 1.4301 (304)
- Brass

### Weight

- 12 kg

### Suitable for

- all common hydrant surface boxes

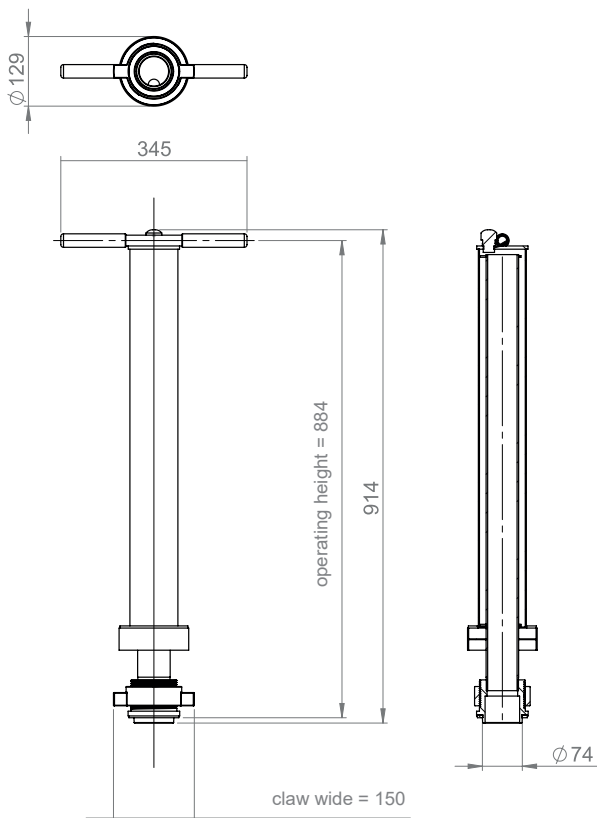

All dimensions in mm.



Surface box cleaning with BÜSCH Surface box cleaner made of stainless steel



Surface box cleaner without BÜSCH Standpipe hygiene lock cap®

### Accessories



Surface box cleaner with mounted BÜSCH Standpipe hygiene lock cap®



Claw cleaning rod for underground hydrant

## YOUR ADVANTAGES

- **HIGH QUALITY & ROBUST**  
The surface box cleaner is made of stainless steel and therefore suitable for drinking water
- **PROTECTION & SAFETY**  
Pipe aerator automatically prevents waste water from returning to the water pipe by automatically opening valve
- **FAST & EASY**  
Measurable cleaning performance - clean water after 10 seconds





# BÜSCH

## Standpipe hygiene lock cap®

made of stainless steel

### Material

- Stainless steel 1.4301 (304)

### Weight

- 1,2 kg

### Suitable for

- all common standpipes



Standpipe hygiene lock cap® made of stainless steel



Application example: Standpipe hygiene lock cap® mounted on BÜSCH Surface box cleaner

### Dimensional drawings

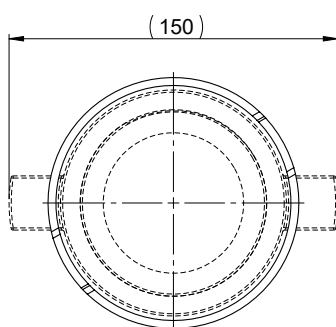
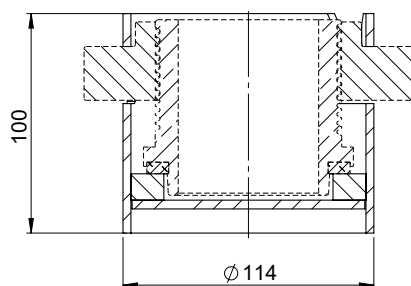

Standpipe hygiene lock cap® with mounted Surface box cleaner

i

### YOUR ADVANTAGES

- **SAFETY & PROTECTION**  
of the standpipe from damage and contamination
- **DURABLE & ROBUST**  
Made of stainless and sturdy stainless steel
- **FAST ASSEMBLY**  
by twist lock
- **COST-NEUTRAL**  
by passing on the purchase price - the hygiene lock cap can be integrated into the deposit of the rented standpipe

2026-01-30-en